



Multi-Flexible-Coupling

GENIUS

- + One coupling for all pipe materials
- + For above and below ground
- + With integrated bushes
- + Resistant to 2.5 bar

Multi-Flexible-Coupling GENIUS – for the connection of all pipe systems with different or same outside diameters

The Multi-Flexible-Coupling GENIUS with integrated bushes joints all plain ended pipes within one dimension and can be used inside and outside of buildings.

The right solution always to hand: What ever pipe material needs to be jointed within one dimension, the GENIUS will always be the right solution for the contractor.



INSTALLATION



Bush at smaller pipe remains integrated – fold out and remove bush at larger pipe.



Slide GENIUS over larger pipe.



Push smaller pipe into GENIUS and tighten clamps and shear band reciprocally.

DESCRIPTION

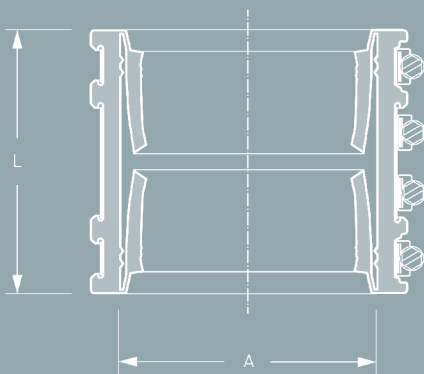

TECHNICAL SPECIFICATION

Multi-Flexible-Coupling GENIUS with integrated bushes for the connection of plain ended pipe materials within one dimension with different or same outside diameters.

Pipe 1 DN/Material _____
 Pipe 2 DN/Material _____
 Article Number _____
 _____ Qty _____ Price/Unit _____ Total

Manufacturer: MISSION RUBBER (UK) LTD., Sheffield, S35 9TG
 T +44 (0) 114 257 - 0040

Pressure Tightness: 2.5 bar water / -0.3 bar vacuum

Jetting Resistance: 120 bar

Corrosion Resistance: TOX®-Technology

Sealing Material: EPDM or Nitrile (NBR) rubber with lock in place profile according to BS EN 681-1

Stainless Steel: AISI 304/1.4301, alternatively AISI 316/1.4404 according to BS EN 10088-2

Temperature Resistance: -40°C to +120°C, temporary max. temperature +160°C

Standard/Approval: BS EN 295-4



PRODUCT RANGE

MULTI-FLEXIBLE-COUPLING GENIUS						
Article Number	Reference	A Size Range (mm)	L Length (mm)	resistant to (bar)	Nm	Weight (kg)
500071	GENIUS DN 100	108 - 137	120	2,5	10,0	1,30
500072	GENIUS DN 125	123 - 162	120	2,5	10,0	1,50
500073	GENIUS DN 150	158 - 192	150	2,5	10,0	2,40

For larger sizes refer to page 15..

APPLICATION SCHEDULES

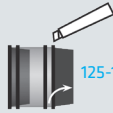
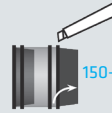
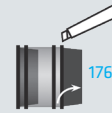
DN 100	GENIUS-OPTION Size Range (mm)	DN 125	GENIUS-OPTION Size Range (mm)	DN 150	GENIUS-OPTION Size Range (mm)
If the pipe OD is between 108mm and 125mm the inner bush needs to remain.		If the pipe OD is between 123mm and 150mm the inner bush needs to remain.		If the pipe OD is between 158mm and 176mm the inner bush needs to remain.	
	108-125  125-137		123-150  150-162		158-176  176-192
If the pipe OD is between 125mm and 137mm the inner bush needs removing.		If the pipe OD is between 150mm and 162mm the inner bush needs removing.		If the pipe OD is between 176mm and 192mm the inner bush needs removing.	